

SIGNAMAX **CONNECTIVITY SYSTEMS**

Signamax™ Connectivity Systems Hardened Ethernet Switch

Model -065-7405TB

065-7408ATB

065-74091FXSTTB

065-74091FXSCTB

U S E R ' S G U I D E



Quick Start Guide

This quick start guide describes how to install and use the **Signamax** hardened Ethernet Switch. This is the switch of choice for harsh environments constrained by space.

Physical Description

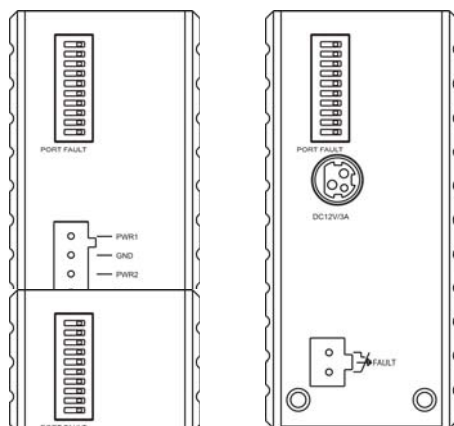
The Terminal Block and Power inputs



Terminal Assignment																					
PWR1	Power Input 1 (12 ~ 48VDC)																				
GND	Power Ground																				
PWR2	Power Input 2 (12 ~ 48VDC)																				
GND	Power Ground																				
	Earth Ground																				
 FAULT	1. The relay opens if PWR1 or PWR2 fails 2. The relay opens if the Port Link is broken (When Link Down Detection is Enabled)																				
<table border="1"> <tr> <td>ON</td> <td></td> <td></td> <td></td> <td></td> <td></td> <td></td> <td></td> <td></td> <td>DIP</td> </tr> <tr> <td>1</td> <td>2</td> <td>3</td> <td>4</td> <td>5</td> <td>6</td> <td>7</td> <td>8</td> <td>9</td> <td>10</td> </tr> </table>	ON									DIP	1	2	3	4	5	6	7	8	9	10	ON: Enable Port Fault Alarm OFF: Disable Port Fault Alarm PIN 10: N/A
ON									DIP												
1	2	3	4	5	6	7	8	9	10												

DC Terminal Block Power Inputs: There are two pairs of power inputs can be used to power up this Switch. Redundant power supplies function is supported. You only need to have one power input connected to run the Switch.

The 10/100BaseT/TX and 100BaseFX Connectors

1. The 10/100BaseT/TX Connections

The following lists the pinouts of 10/100BaseT/TX ports.



Pin	Regular Ports	Uplink port
1	Input Receive Data +	Output Transmit Data +
2	Input Receive Data -	Output Transmit Data -
3	Output Transmit Data +	Input Receive Data +
4	NC	NC
5	NC	NC
6	Output Transmit Data -	Input Receive Data -
7	NC	NC
8	NC	NC

2. The 100BaseFX Connections

The fiber port pinouts: The Tx (transmit) port of device I is connected to the Rx (receive) port of device II, and the Rx (receive) port of device I to the Tx (transmit) port of device II.

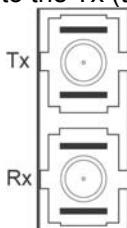

The Port Status LEDs

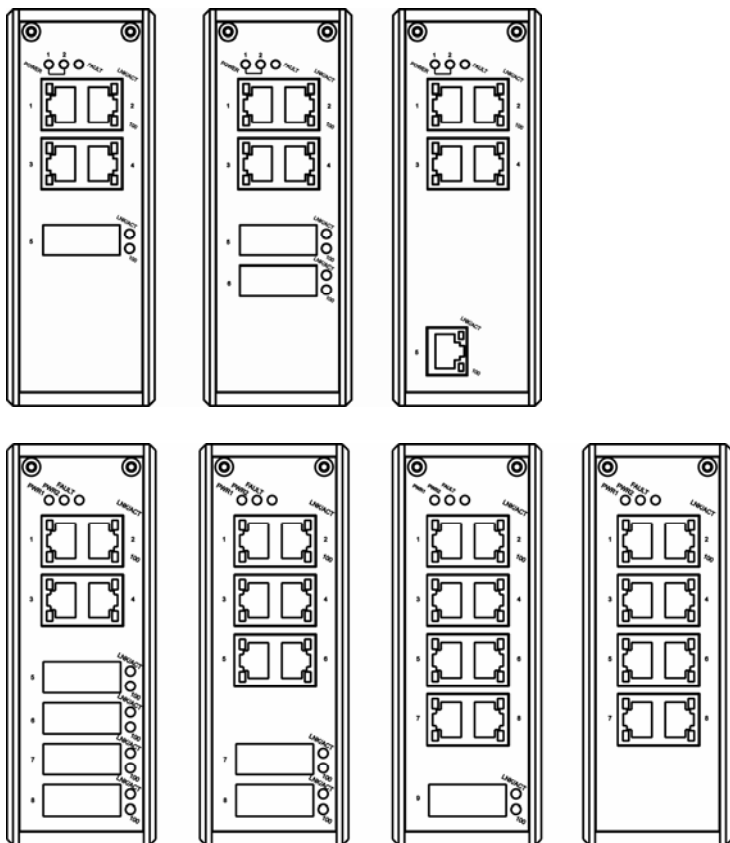

Functional Description

- Meets NEMA TS1/TS2 Environmental requirements such as temperature, shock, and vibration for traffic control equipment.
- Meets IEC61000-6-2 EMC Generic Standard Immunity for industrial environment.
- UL1604 Class 1, Division 2 Classified for use in hazardous locations.
- Support 802.3/802.3u/802.3x. Auto-negotiation: 10/100Mbps, full/half-duplex; Auto MDI/MDIX.
- **100BaseFX**: Multi mode SC or ST type; Single mode SC or ST type; WDM Single mode SC type.
- Support 2048 MAC addresses. Provides 768K bits memory buffer.
- Alarms for power and port link failure by relay output.
- Operating voltage and Max. current consumption: 0.76A @ 12VDC, 0.38A @ 24VDC, 0.19A @ 48VDC. Power consumption: 9.12W Max.
- **Power Supply: Redundant DC Terminal Block power inputs with 100-240VAC external power supply.**
- -40°C to 75°C (-40°F to 167°F) operating temperature range. Tested for functional operation @ -40°C to 85°C (-40°F to 185°F).
- Supports DIN-Rail or Panel Mounting installation.

LED	State	Indication
POWER		
PWR1 PWR2 (Green)	Steady	Switch is properly connected to power and turned on.
	Off	Switch is not connected to power and is turned off.
FAULT		
FAULT (Red)	Steady	1. Power failure occurred. 2. Port failure occurred (when port fault alarm dip switch is enabled).
	Off	1. Power failure is not occurred. 2. Port failure is not occurred (when port fault alarm dip switch is enabled). 3. Port fault alarm dip switch is disabled.
10/100BaseT/TX or 100BaseFX		
LNK/ACT (Green)	Steady	A valid network connection established. LNK stands for LINK.
	Flashing	Transmitting or receiving data. ACT stands for ACTIVITY.
100 (Yellow)	Steady	Light solid yellow for a port transferring at 100Mbps.
	Off	The port is transferring at 10Mbps If this LED is dark.

Assembly, Startup, and Dismantling

- **Assembly:** Place the switch on the DIN rail from above using the slot. Push the front of the switch toward the mounting surface until it audibly snaps into place.
- **Startup:** Connect the supply voltage to start up the switch via the terminal block.
- **Dismantling:** Pull out the lower edge and then remove the switch from the DIN rail.

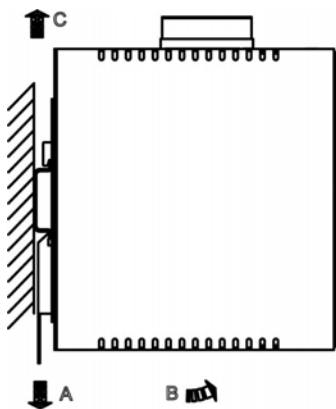
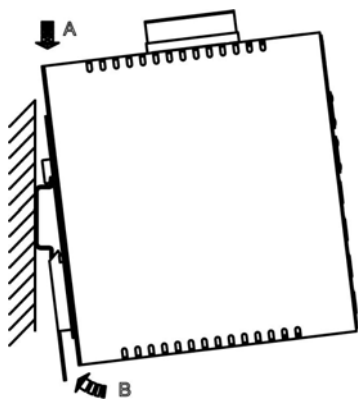

Preface

A member of the growing Signamax family of harsh environment switches, this switch addresses a need for a smaller switch. This switch provides an affordable solution for rugged and outdoor environment, transportation road-side cabinet, industrial floor shop, multitenant dwellings or Fiber To The Home (FTTH) applications. Capable of operating at temperature extremes of -40°C to $+75^{\circ}\text{C}$, this is the switch of choice for harsh environments constrained by space.

Plug-and-Play Solution:

The switch is a plug-and-play Fast Ethernet Switch in compact size. It doesn't have any complicated software to set up.

This manual describes how to install and use the hardened Ethernet Switch. This switch integrates full wire speed switching technology. This switch brings the answer to complicated hardened networking environments.

To get the most out of this manual, you should have an understanding of Ethernet networking concepts.

In this manual, you will find:

- Features on the switch
- Illustrative LED functions
- Installation instructions
- Specifications

Table of Contents

QUICK START GUIDE	2
PHYSICAL DESCRIPTION	2
<i>The Terminal Block and Power inputs.....</i>	<i>2</i>
<i>The 10/100BaseT/TX and 100BaseFX Connectors</i>	<i>3</i>
<i>The Port Status LEDs.....</i>	<i>4</i>
FUNCTIONAL DESCRIPTION	5
ASSEMBLY, STARTUP, AND DISMANTLING.....	6
PREFACE.....	8
TABLE OF CONTENTS	9
PRODUCT OVERVIEW.....	10
HARDENED ETHERNET SWITCH.....	10
PACKAGE CONTENTS	11
PRODUCT HIGHLIGHTS	11
<i>Basic Features.....</i>	<i>11</i>
FRONT PANEL DISPLAY.....	12
PHYSICAL PORTS	13
INSTALLATION	14
SELECTING A SITE FOR THE SWITCH	14
DIN RAIL MOUNTING	15
CONNECTING TO POWER	16
<i>Redundant DC Terminal Block Power Inputs.....</i>	<i>16</i>
<i>Alarms for Power and Port Failure.....</i>	<i>17</i>
CONNECTING TO YOUR NETWORK	18
<i>Cable Type & Length.....</i>	<i>18</i>
<i>Cabling.....</i>	<i>19</i>
SPECIFICATIONS.....	20
APPENDIX A – CONNECTOR PINOUTS.....	22
CONTACT INFORMATION.....	23

Product Overview

Hardened Ethernet Switch

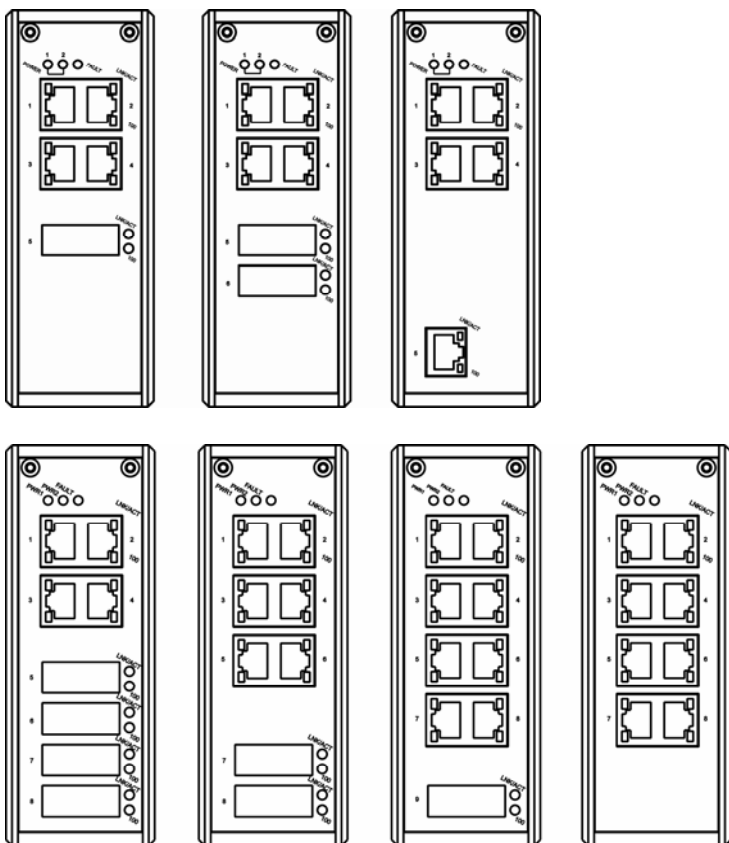

Package Contents

When you unpack the product package, you shall find the items listed below. Please inspect the contents, and report any apparent damage or missing items immediately to your authorized reseller.

- ✓ ***This Switch***
- ✓ ***User's Manual***
- ✓ ***External power adapter & Power Cord (Optional)***

Product Highlights

Basic Features

- Meets NEMA TS2 Environmental requirements such as temperature, shock, and vibration for traffic control equipment.
- Meets IEC61000-6-2 EMC Generic Standard Immunity for industrial environment.
- UL1604 Class 1, Division 2 Classified for use in hazardous locations.
- Support 802.3/802.3u/802.3X.
- Auto-negotiation: 10/100Mbps, Full/half-duplex; Auto MDI/MDIX.
- Support 2048 MAC addresses.
- Provides 768K bits memory buffer.
- Alarms for power and port link failure by relay output.
- Operating voltage and Max. current consumption: 0.76A @ 12VDC, 0.38A @ 24VDC, 0.19A @ 48VDC. Power consumption: 9.12W Max.
- **Power Supply: Redundant DC Terminal Block power inputs with 100-240VAC external power supply.**
- -40°C to 75°C (-40°F to 167°F) operating temperature range. Tested for functional operation @ -40°C to 85°C (-40°F to 185°F).

- Supports DIN-Rail or Panel Mounting installation.

Front Panel Display

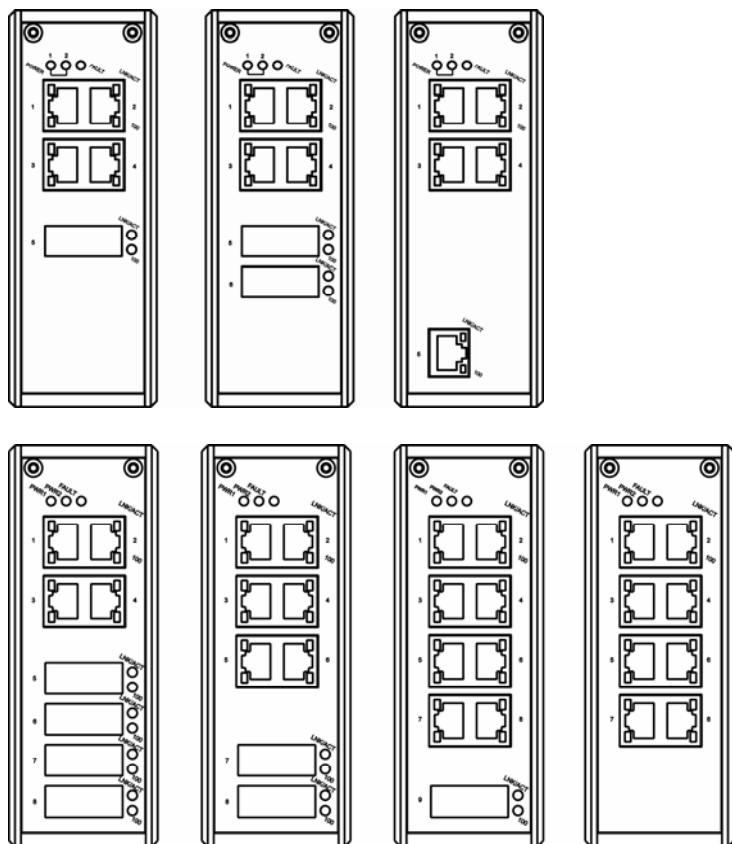

Status LEDs

LED	State	Indication
POWER		
PWR1 PWR2 (Green)	Steady	Switch is properly connected to power and turned on.
	Off	Switch is not connected to power and is turned off.
FAULT		
FAULT (Red)	Steady	3. Power failure occurred. 4. Port failure occurred (when port fault alarm dip switch is enabled).
	Off	3. Power failure is not occurred. 4. Port failure is not occurred (when port fault alarm dip switch is enabled). 3. Port fault alarm dip switch is disabled.
10/100BaseT/TX or 100BaseFX		
LNK/ACT (Green)	Steady	A valid network connection established. LNK stands for LINK.
	Flashing	Transmitting or receiving data. ACT stands for ACTIVITY.
100 (Yellow)	Steady	Light solid yellow for a port transferring at 100Mbps.
	Off	The port is transferring at 10Mbps If this LED is dark.

Physical Ports

This switch provides:

- Five **10/100BaseT/TX** ports
- Four **10/100BaseT/TX** ports + one **100BaseFX** port
- Four **10/100BaseT/TX** ports + two **100BaseFX** ports
- Eight **10/100BaseT/TX** ports
- Eight **10/100BaseT/TX** ports + one **100BaseFX** port
- Six **10/100BaseT/TX** ports + two **100BaseFX** ports
- Four **10/100BaseT/TX** ports + four **100BaseFX** ports

CONNECTIVITY

- RJ-45 connectors
- SC or ST connector on **100BaseFX** fiber port

Installation

This chapter gives step-by-step instructions about how to install the switch:

Selecting a Site for the Switch

As with any electric device, you should place the switch where it will not be subjected to extreme temperatures, humidity, or electromagnetic interference. Specifically, the site you select should meet the following requirements:

- The ambient temperature should be between -40 to 75 degrees Celsius.
- The relative humidity should be less than 95 percent, non-condensing.
- Surrounding electrical devices should not exceed the electromagnetic field (RFC) standards.
- Make sure that the switch receives adequate ventilation. Do not block the ventilation holes on each side of the switch
- The power outlet should be within 1.8 meters of the switch.

DIN Rail Mounting

Fix the DIN rail attachment plate to the back panel of the switch.

Installation: Place the switch on the DIN rail from above using the slot. Push the front of the switch toward the mounting surface until it audibly snaps into place.

Removal: Pull out the lower edge and then remove the switch from the DIN rail.

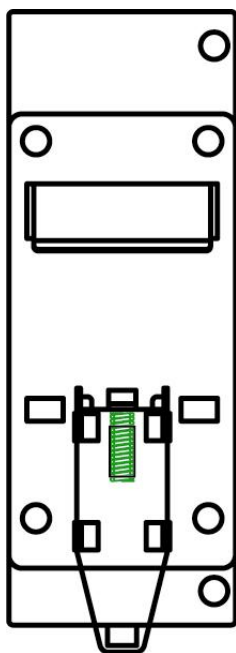

Connecting to Power

Redundant DC Terminal Block Power Inputs

There are two pairs of power inputs can be used to power up this device. You only need to have one power input connected to run the switch.

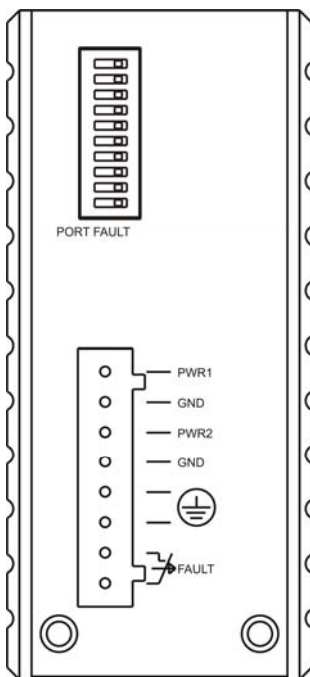

Step 1: Connect the DC power cord to the plug-able terminal block on the switch, and then plug it into a standard DC outlet.

Step 2: Disconnect the power cord if you want to shut down the switch.



Alarms for Power and Port Failure

Step 1: There are two pins on the terminal block are used for power failure detection. It provides the normally closed output when the power source is active. Use this as a dry contact application to send a signal for power failure detection.

Terminal Assignment	
PWR1	Power Input 1 (12 ~ 48VDC)
GND	Power Ground
PWR2	Power Input 2 (12 ~ 48VDC)
GND	Power Ground
	Earth Ground
	1. The relay opens if PWR1 or PWR2 fails 2. The relay opens if the Port Link is broken (When Link Down Detection is Enabled)

ON DIP 	ON: Enable Port Fault Alarm OFF: Disable Port Fault Alarm PIN 10: N/A
--	---

Special note:

The relay output is normal open position when there is no power to the switch. Please do not connect any power source to this terminal to prevent the shortage to your power supply.

Connecting to Your Network

Cable Type & Length

It is necessary to follow the cable specifications below when connecting the switch to your network. Use appropriate cables that meet your speed and cabling requirements.

Cable Specifications

Speed	Connector	Port Speed Half/Full Duplex	Cable	Max. Distance
10BaseT	RJ-45	10/20 Mbps	2-pair UTP/STP Cat. 3, 4, 5	100 m
100BaseTX	RJ-45	100/200 Mbps	2-pair UTP/STP Cat. 5	100 m
100BaseFX	SC, ST	100/200 Mbps	MMF (50 or 62.5 μ m)	2 km
100BaseFX	SC, ST	100/200 Mbps	SMF (9 or 10 μ m)	15, 40, or 75 km

Cabling

Step 1: First, ensure the power of the switch and end devices are turned off.

<Note> Always ensure that the power is off before any installation.

Step 2: Prepare cable with corresponding connectors for each type of port in use.

Step 3: Consult the previous section for cabling requirements based on connectors and speed.

Step 4: Connect one end of the cable to the switch and the other end to a desired device.

Step 5: Once the connections between two end devices are made successfully, turn on the power and the switch is operational.

Specifications

Hardened Ethernet Switch	10/100BaseT/TX auto-negotiating ports with RJ-45 connectors, 100BaseFX fiber ports
Applicable Standards	IEEE 802.3 10BaseT IEEE 802.3u 100BaseTX/FX
Switching Method	Store-and-Forward
Forwarding Rate	
10BaseT:	10 / 20Mbps half / full-duplex
100BaseTX/FX:	100 / 200Mbps half / full-duplex
Performance	14,880pps for 10Mbps 148,810pps for 100Mbps
Cable	
10BaseT:	2-pair UTP/STP Cat. 3, 4, 5
100BaseTX:	2-pair UTP/STP Cat. 5 Up to 100m (328ft)
100BaseFX:	MMF (50 or 62.5µm), SMF (9 or 10µm)
LED Indicators	Per unit – Power status (Power 1, Power 2) FAULT Per port – 10/100BaseT/TX or 100BaseFX - LNK/ACT (Green), 100 (Yellow)
Dimensions	50mm (W) × 110mm (D) × 135mm (H) (1.97" (W) x 4.33" (D) x 5.31" (H))
Net Weight	0.8Kg (1.76lbs.)
Power	Terminal Block: 12-48VDC
Operating Voltage & Max. Current Consumption	0.76A @ 12VDC, 0.38A @ 24VDC, 0.19A @ 48VDC
Power Consumption	9.12W Max.
Operating Temperature	-40°C to 75°C (-40°F to 167°F) Tested for functional operation @ -40°C to 85°C (-40°F to 185°F)
Storage Temperature	-45°C to 85°C (-40°F to 185°F)
Humidity	5%-95% non-condensing
Safety	Hazardous location: Class 1, Division 2 group A, B, C & D UL60950-1, EN60950-1, IEC60950-1
EMI	FCC Part 15, Class A EN61000-6-3: EN55022, EN61000-3-2, EN61000-3-3

EN61000-6-2:

EN61000-4-2 (ESD Standards)

EN61000-4-3 (Radiated RFI Standards)

EN61000-4-4 (Burst Standards)

EN61000-4-5 (Surge Standards)

EN61000-4-6 (Induced RFI Standards)

EN61000-4-8 (Magnetic Field Standards)

EN61000-4-11 (Voltage Dip Standards)

Environmental Test Compliance

IEC60068-2-6 Fc (Vibration Resistance)

IEC60068-2-27 Ea (Shock)

IEC60068-2-32 Ed (Free Fall)

NEMA TS1/2 Environmental requirements for traffic control equipment

Appendix A – Connector Pinouts

Pin arrangement of RJ-45 connectors:

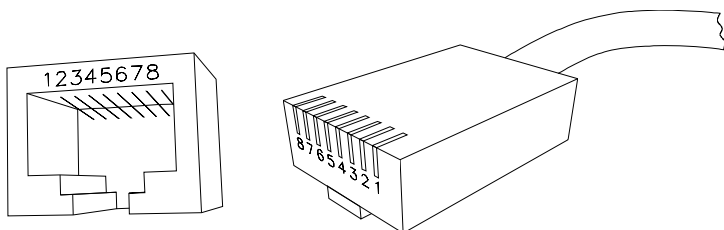

RJ-45 Connector and Cable Pins

The following table lists the pinout of **10/100BaseT/TX** ports.

Pin	Regular Ports	Uplink port
1	Input Receive Data +	Output Transmit Data +
2	Input Receive Data -	Output Transmit Data -
3	Output Transmit Data +	Input Receive Data +
4	NC	NC
5	NC	NC
6	Output Transmit Data -	Input Receive Data -
7	NC	NC
8	NC	NC

Contact Information

SIGNAMAX[™] CONNECTIVITY SYSTEMS

An AESP Company

1810 N.E. 144th Street.

North Miami, Florida 33181, U.S.A.

Phone: 305-944-7710 Fax: 305-652-8489

Sales: 800-446-2377 Tech. Support: 800-446-2377, ext. 201

[Http://www.signamax.com](http://www.signamax.com)

E-mail: info@signamax.com