

Single Pole (One location) or 3-Way (Multi-location)  
**Electronic Switch**  
Cat. No. ACS15-1L (Lighted)  
Incandescent-1800W – Magnetic Low-Voltage-1800VA (1440W)  
Electronic Low-Voltage-1800W – Fluorescent-1800VA – Supplemental-1/2 HP  
120VAC, 60Hz

**INSTALLATION INSTRUCTIONS**

**WARNINGS AND CAUTIONS:**

- To be installed and/or used in accordance with appropriate electrical codes and regulations.
- If you are unsure about any part of these instructions, consult a qualified electrician.
- Acenti™ electronic switches are not compatible with standard 3-way or 4-way switches. They must be used with compatible Acenti™ on/off remotes.
- Recommended minimum wall box depth is 2-1/2".

**WARNINGS AND CAUTIONS:**

- Use only one (1) electronic switch in a multi-location circuit with up to 9 coordinating remotes without LEDs or up to 4 matching remotes with LEDs.
- Maximum wire length from dimmer to all installed remotes cannot exceed 300 ft.
- Disconnect power at circuit breaker or fuse when servicing, installing or removing fixture.
- Use this device only with copper or copper clad wire. With aluminum wire use only devices marked CO/ALR or CU/AL.

**Tools needed to install your Switch:**

- Slotted/Phillips Screwdriver    Electrical Tape    Pliers  
Pencil    Cutters    Ruler

**INSTALLING YOUR SWITCH**

**NOTE:** Use check boxes  when Steps are completed.

**Step 1** **WARNING: TO AVOID FIRE, SHOCK, OR DEATH; TURN OFF POWER** at circuit breaker or fuse and test that power is off before wiring!

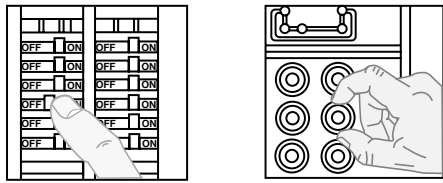

**Step 2** **Identifying your wiring application (most common):**

**NOTE:** If the wiring in the wall box does not resemble any of these configurations, consult a qualified electrician.

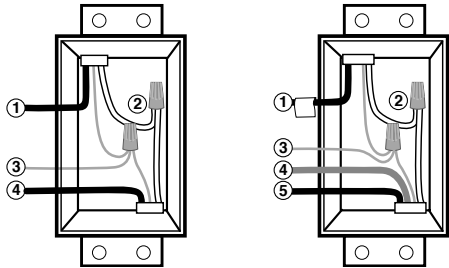

**Single-Pole**

- Line (Hot)
- Neutral
- Ground
- Load

**3-Way**

- Line or Load (*See important\* instruction*)
- Neutral
- Ground
- First Traveler – note color
- Second Traveler – note color

**NOTE:** For matching remote w/LEDs installation, the **First Traveler** becomes Line Hot.

**\* IMPORTANT:** For 3-Way applications, note that one of the screw terminals from the old switch being removed will usually be a different color (Black) or labeled Common. Tag that wire with electrical tape and identify as the common (Line or Load) in both the switch wall box and remote wall box.

**Step 3** **Preparing and connecting wires:**

This switch can be wired using side wire terminal screws or through backwire openings. Choose appropriate wire stripping specifications accordingly.

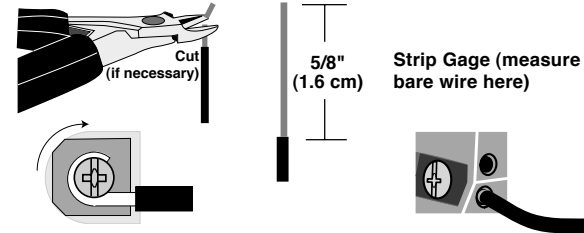

**Side Wire Connection**

Side wire terminals accept #14 AWG solid copper wire only.

**Back Wire (either hole may be used)**

Back wire openings use #14-12 AWG solid copper wire only.

- Make sure that the ends of the wires from the wall box are **straight (cut if necessary)**.
- Remove insulation from each wire in the wall box as shown.

**Step 4** **Installing your Alignment Plate:**

**Important Notice for Installer**

To achieve proper aesthetic installation of the Acenti products, the wall surface surrounding the wall box opening must be fairly flat and free of irregularities. The wall box must be level and recessed or flush to the wall surface. The Acenti installation system allows for adjustments that will correct minor flaws that may be present in the installation area.

This device must be installed with the Acenti™ Alignment Plate. The Alignment Plate is packaged with the Acenti™ Wallplate, which is sold separately from this device.

The Alignment Plate will function properly only if it is mounted to a flat wall surface as described above.

**Step 4 cont'd**

- Leviton recommends to temporarily position the Alignment Plate prior to wiring the device. If the wall box wires extend at least 6 inches out of the wall box, it is also possible to install the Alignment Plate after the device has been wired (*refer to Wallplate instruction sheet*).
- The Alignment Plate must be installed with the tab towards the bottom.
- Leviton recommends the following 3 methods to temporarily hold the Alignment Plate – use of device mounting screw, use of wall box wires, or use of electrical tape (*refer to the following figures*):

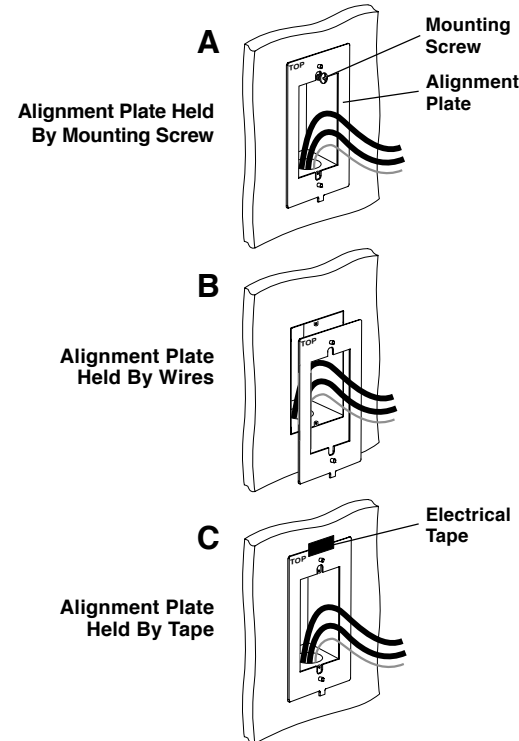

**Step 5a** **Installing your Switch – Single-Pole Wiring Application:**

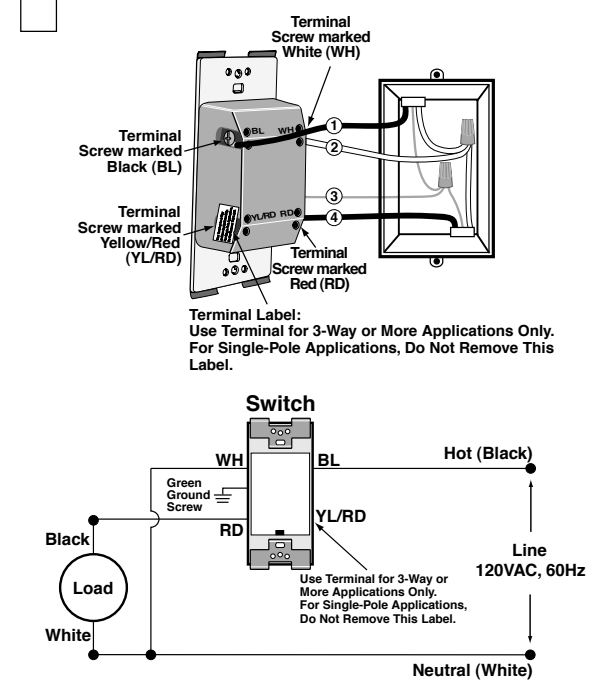

**WIRING SWITCH:**

Connect wires per **WIRING DIAGRAM** as follows:

- Green or bare copper wire in wall box to Green terminal screw.
- Line Hot wall box wire to terminal screw marked "BL".
- Load wall box wire to terminal screw marked "RD".
- Line Neutral wall box wire to terminal screw marked "WH".
- Switch terminal screw marked "YL/RD" should have Red insulation label affixed.

**NOTE:** If insulating label is not affixed to terminal screw marked "YL/RD", use electrical tape to cover.

Proceed to **Step 6**.

- For Single-Pole Application, go to **Step 5a**.
- For 3-Way Coordinating Remote (no LEDs) Application, go to **Step 5b**.
- For 3-Way Matching Remote (with LEDs) Application, go to **Step 5c**.

### Step 5b 3-Way Wiring with Coordinating Remote (no LED) Application:

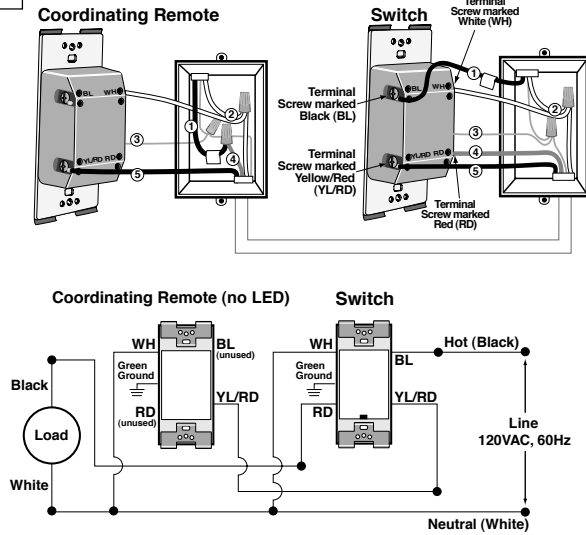

#### WIRING SWITCH:

**Connect wires per WIRING DIAGRAM as follows:**

- NOTE:** The switch **must** be installed in a wall box that has a Line Hot connection.
- NOTE:** Maximum wire length from switch to all installed remotes cannot exceed 300 ft.
- Green or bare copper wire in wall box to Green terminal screw.
  - Line Hot (common) wall box wire identified (tagged) to terminal screw marked "BL".
  - First Traveler wall box wire to terminal screw marked "RD" (**note wire color**).
  - Remove Red insulating label from terminal screw marked "YL/RD".
  - Second Traveler wall box wire to terminal screw marked "YL/RD" (**note wire color**). This traveler from the switch must go to the terminal screw on the remote marked "YL/RD".
  - Line Neutral wall box wire to terminal screw marked "WH".

#### WIRING COORDINATING REMOTE:

##### Connect wires per WIRING DIAGRAM as follows:

**NOTE:** "BL" and "RD" terminals on coordinating remote are unused. Tighten both screws.

- NOTE:** Maximum wire length from switch to last remote is 300 ft.
- Green or bare copper wire in wall box to Green terminal screw.
  - Load wall box wire identified (tagged) when removing old switch to First Traveler (**note color as above**).
  - Second Traveler wall box wire (**note color as above**) to terminal screw marked "YL/RD". This traveler from the remote must go to the terminal screw on the switch marked "YL/RD".
  - Remove White insulating label from terminal screw marked "WH".
  - Line Neutral wall box wire to terminal screw marked "WH".
  - **Proceed to Step 6.**

### Step 5c 3-Way Wiring with Matching Remote (w/LED) Application:

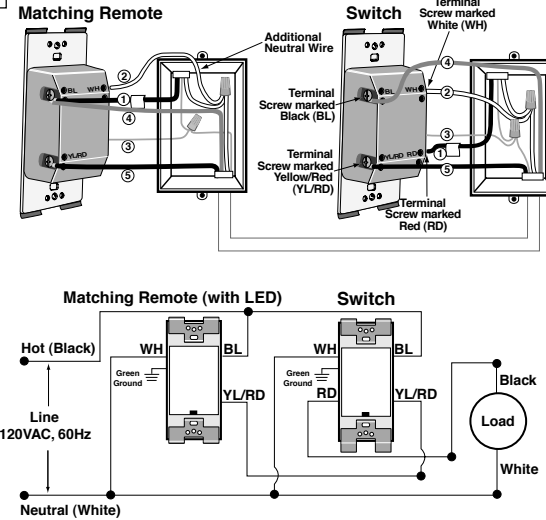

**NOTE:** The switch **must** be installed in a wall box that has a Load connection. The matching remote **must** be installed in a wall box with a Line Hot connection and a Neutral connection. A Neutral wire to the matching remote needs to be added as shown.

If you are unsure about any part of these instructions, consult a qualified electrician.

**NOTE:** Maximum wire length from switch to all installed remotes cannot exceed 300 ft.

#### WIRING MATCHING REMOTE (wall box with Line Hot connection):

##### Connect wires per WIRING DIAGRAM as follows:

- Green or bare copper wire in wall box to Green terminal screw.
- Line Hot (common) wall box wire identified (tagged) when removing old switch and First Traveler to switch terminal screw marked "BL".
- Second Traveler wall box wire from switch to remote terminal screw marked "YL/RD" (**note wire color**). This traveler from the remote must go to the terminal screw on the switch marked "YL/RD".
- Line Neutral wall box wire to remote terminal screw marked "WH".

#### WIRING SWITCH (wall box with Load connection):

##### Connect wires per WIRING DIAGRAM as follows:

- Green or bare copper wire in wall box to Green terminal screw.
- Load wall box wire identified (tagged) when removing old switch to terminal screw marked "RD".
- First Traveler Line Hot to terminal screw marked "BL".
- Remove Red insulating label from terminal screw marked "YL/RD".
- Second Traveler wall box wire (**note color as above**) to terminal screw marked "YL/RD". This traveler from the switch must go to the terminal screw on the remote marked "YL/RD".
- Line Neutral wall box wire to remote terminal screw marked "WH".
- **Proceed to Step 6.**

### Step 6 Testing your Switch prior to completely mounting in wall box:

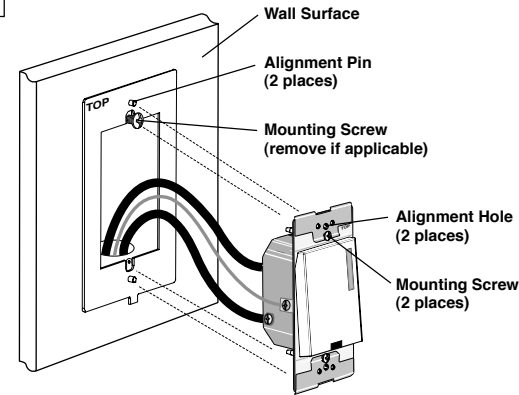

- If Alignment Plate is temporarily positioned using screw as in **Step 4A**, remove screw at this point.
- Position all wires to provide room in outlet wall box for device.
- Ensure that the word "TOP" is facing up on the device strap.
- Partially screw in mounting screws in wall box mounting hole.

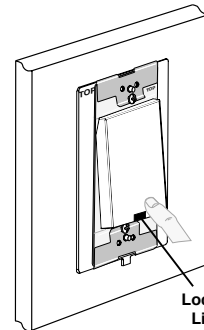

- Restore power at circuit breaker or fuse.
  - Lights should turn ON. If lights do not turn ON, tap push pad.
- If lights still do not turn ON, refer to the TROUBLESHOOTING section.**

### Step 7 Switch Mounting:

To complete the Acenti™ Switch and Wallplate installation, please refer to the instructions included with the Acenti™ Wallplate and Alignment Plate.

### OPERATION

**NOTE:** The locator light will illuminate when the load is in the OFF position to facilitate access in the dark.

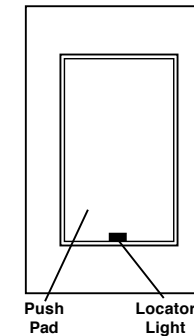

#### Push Pad (Default settings)

**Turn ON from OFF position:**  
Tap – Lights turn ON.

**Turn OFF from ON position:**  
Tap – Lights turn OFF.

If there is a power outage, the lights will return to the last state before the power interruption, when the power is restored.

**NOTE:** This device has a removable push pad. If there is a need to re-install the push pad, proceed as follows:

- Line up tabs located on top back of pad with openings in the top of strap and gently press in.
- Line up tab located on bottom back of pad with opening in the bottom of strap and gently press in.
- Press bottom of push pad to re-engage.

**Cleaning:** Clean with a damp cloth. **DO NOT** use chemical cleaners.

### TROUBLESHOOTING

- **Lights Flickering**
  - Lamp has a bad connection.
  - Wires not secured firmly under terminal screws of switch and/or remote.
- **Light does not turn ON and Locator LED does not turn ON**
  - Circuit breaker or fuse has tripped.
  - Lamp is burned out.
  - Lamp Neutral connection is not wired.
- **Remote does not operate lights**
  - Ensure that total wire length does not exceed 300 ft.

For additional information, contact the Acenti™ Information Hotline at 1-888-4-ACENTI or visit Leviton's website at [www.leviton.com/acenti](http://www.leviton.com/acenti)

U.S. & Foreign Patents Pending  
Copyright© 2004 Leviton Manufacturing Co., Inc.  
All Rights Including Trade Dress Rights Reserved

### LIMITED 5 YEAR WARRANTY AND EXCLUSIONS

Leviton warrants to the original consumer purchaser and not for the benefit of anyone else that this product at the time of its sale by Leviton is free of defects in materials and workmanship under normal and proper use for five years from the purchase date. Leviton's only obligation is to correct such defects by repair or replacement, at its option, if within such five year period the product is returned prepaid, with proof of purchase date, and a description of the problem to **Leviton Manufacturing Co., Inc., Attn: Quality Assurance Department, 59-25 Little Neck Parkway, Little Neck, New York 11362-2591**. This warranty excludes and there is disclaimed liability for labor for removal of this product or reinstallation. This warranty is void if this product is installed improperly or in an improper environment, overloaded, misused, opened, abused, or altered in any manner, or is not used under normal operating conditions or not in accordance with any labels or instructions. **There are no other or implied warranties of any kind, including merchantability and fitness for a particular purpose**, but if any implied warranty is required by the applicable jurisdiction, the duration of any such implied warranty, including merchantability and fitness for a particular purpose, is limited to five years. **Leviton is not liable for incidental, indirect, special, or consequential damages, including without limitation, damage to, or loss of use of, any equipment, lost sales or profits or delay or failure to perform this warranty obligation.** The remedies provided herein are the exclusive remedies under this warranty, whether based on contract, tort or otherwise.