

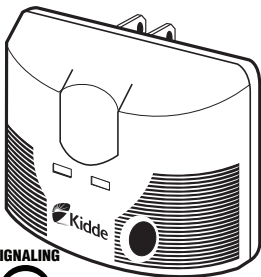

AC Powered

# Carbon Monoxide Alarm

## User's Guide



SIGNALING



LISTED

Kidde Direct Plug CO Alarm Models:  
KN-COB-DP-H  
Basic AC CO Alarm  
KN-COB-LCB-A  
Basic Alarm with Battery Backup and  
Tamper-Resist Features.

*For questions concerning your  
Carbon Monoxide Alarm, please  
call our Consumer Hotline at  
1-800-880-6788*

*Please have the following  
information ready when calling:*

|   |
|---|
| CO Alarm Model Number (Located on the back of alarm): |
| CO Alarm Assembly Number (Located on back of alarm):  |
| Date of Manufacture (Located on back of alarm):       |
| Date of Purchase:                                     |
| Where Purchased:                                      |

**ATTENTION:** Please take a few minutes to thoroughly read this manual, which should be saved for future reference and passed on to any subsequent owner. If you have any questions about the operation or installation of your alarm, please call our toll free Consumer Hotline at 1-800-880-6788.

# Contents

---

## Introduction

## Quick Set Up Guide

### Part One – Your Kidde CO Alarm

- About your CO alarm
- What CO alarms can and cannot do
- Where to install your alarm
- Where not to install your alarm
- How to install your alarm
- Normal operating characteristics
- Testing the electronics
- How to know if your alarm is malfunctioning
- How to care for your alarm

### Part Two – Carbon Monoxide

- The effects of CO exposure
- Could your family be at risk for CO poisoning?
- Where CO comes from
- Protecting your family from CO poisoning
- Home safety tips

### Part Three – What You Should Know Before the Alarm Sounds

- Understand the effects of carbon monoxide exposure

### Part Four – What to Do When the Unit Alarms

- How to respond to the alarm

### Part Five – Technical Information

- Product Specifications
- How the unit determines when to alarm

## Limited Warranty

- Limited Warranty

# Introduction

---

Keep the guide in a handy location and refer to it when you have questions about your CO alarm, its functions, features, or if you have questions about carbon monoxide. Please read this guide in the sequence presented. You will then know how to use your CO alarm wisely and to know how to react in the event of an alarm

## **IMPORTANT**

**THIS CARBON MONOXIDE ALARM IS DESIGNED TO DETECT CARBON MONOXIDE FROM ANY SOURCE OF IMPROPER OR MALFUNCTIONING APPLIANCES. IT IS NOT DESIGNED TO DETECT SMOKE, FIRE, OR ANY OTHER GAS.**



## **WARNING!**

**CO ALARMS ARE NOT SMOKE ALARMS. CO ALARMS DO NOT SENSE SMOKE OR FIRE. FOR EARLY WARNING OF FIRE YOU MUST INSTALL SMOKE ALARMS, EVEN THOUGH CARBON MONOXIDE CAN BE GENERATED BY FIRE. THIS CARBON MONOXIDE ALARM IS NOT A SUBSTITUTE FOR INSTALLING AND MAINTAINING AN APPROPRIATE NUMBER OF SMOKE ALARMS IN YOUR HOME. FOR THIS REASON YOU MUST INSTALL SMOKE ALARMS TO PROVIDE EARLY WARNING OF FIRE AND TO PROTECT YOU AND YOUR FAMILY FROM FIRE AND ITS RELATED HAZARDS.**

**THIS PRODUCT IS INTENDED FOR USE IN ORDINARY INDOOR RESIDENTIAL AREAS. IT IS NOT DESIGNED TO MEASURE COMPLIANCE WITH COMMERCIAL AND INDUSTRIAL STANDARDS. IT IS NOT SUITABLE FOR INSTALLATION IN HAZARDOUS LOCATIONS AS DEFINED IN THE NATIONAL ELECTRIC CODE.**

**MODELS WITHOUT BATTERY BACKUP WILL NOT OPERATE DURING POWER FAILURE. MODEL KN-COB-DP-H WILL NOT WORK WITHOUT POWER. THIS CO ALARM REQUIRES A CONTINUOUS SUPPLY OF ELECTRICAL POWER.**

**MODEL KN-COB-LCB-A REQUIRES A CONTINUOUS SUPPLY OF ELECTRICAL POWER. DURING A POWER OUTAGE IT WILL WORK FOR AT LEAST 20 HOURS IF A BATTERY WITH FULL CAPACITY IS INSTALLED PROPERLY.**

**THE INSTALLATION OF THIS DEVICE SHOULD NOT BE USED AS A SUBSTITUTE FOR PROPER INSTALLATION, USE AND MAINTENANCE OF FUEL-BURNING APPLIANCES, INCLUDING APPROPRIATE VENTILATION AND EXHAUST SYSTEMS.**

**INDIVIDUALS WITH MEDICAL PROBLEMS MAY CONSIDER USING WARNING DEVICES THAT PROVIDE AUDIBLE AND VISUAL SIGNALS FOR CARBON MONOXIDE CONCENTRATIONS UNDER 30 PPM.**

**CAUTION: THIS ALARM WILL ONLY INDICATE THE PRESENCE OF CO GAS AT THE SENSOR. CO MAY BE PRESENT IN OTHER AREAS.**

## Introduction

---

This Kidde carbon monoxide (CO) alarm is an important part of your family's home safety plan. As a new owner of a CO alarm, there are some basic facts you should know for your protection *and* convenience.

Many people think that CO alarms operate like smoke alarms. Like smoke alarms, CO alarms monitor the air in your home and sound a loud alarm to warn you of trouble.

The way you respond to a CO alarm is quite different than a smoke alarm. That's because a house fire and a carbon monoxide problem are two distinctly different situations. If your smoke alarm were to alarm, you would quickly be able to judge the level of danger you were in with your senses. You can see and smell the smoke, feel the heat, see, and possibly hear the fire burning. You can also readily see if your smoke alarm is alarming in a non-emergency situation, for example toast burning in the kitchen. Because your sense of sight, smell, hearing and touch give you information, you can almost instantly judge what action to take if you hear your smoke alarm.

Carbon monoxide (CO) is an invisible, odorless, tasteless and non-irritating gas—completely undetectable to your senses. That's why it is so important to your safety that you have a carbon monoxide alarm.

Please take the time to completely read this guide to familiarize yourself with the facts about carbon monoxide, how your new unit works, and what to do if it alarms. Find a handy place to keep this manual so that it will be readily available when you have a question.

Thank you for making Kidde a part of your complete home safety program. With proper installation and use, your new Kidde CO alarm will provide you with years of dependable service.

## Quick Set Up Guide

---

**We urge you to read this entire manual in the sequence it is presented.**

Listed below are five easy steps for setting up your Kidde CO alarm. Please read the entire guide for complete information.

**Setting up your CO alarm for first time operation:**

### Step 1

Determine the best location for your CO alarm(s). Usually this is in or near bedrooms. Refer to Part One, Where to Install Your CO Alarm for complete information.

### Step 2

For model KN-COB-LCB-A remove the yellow pull-tab or install the battery shipped with your unit

Plug the CO alarm into a standard, unswitched 120 volt AC electric outlet.

### Step 3

The green Operate light will come on and stay on showing the CO alarm is receiving power.

### Step 4

Next, test the alarm's operation by pressing and releasing the Test/Reset button. The unit will beep quickly 4 times – followed by 5 seconds of silence – followed by 4 quick beeps. This is also the alarm cycle in the event of a CO problem. Familiarize yourself and household members with this alarm pattern. The red alarm light will come on when the alarm sounds.

### Step 5

While testing the CO alarm, have someone else check that the alarm can be heard easily from the sleeping areas. The CO alarm should be located where it can wake you if it alarms at night.

Your Kidde CO alarm is now monitoring for the presence of carbon monoxide.

# Part One – Your Kidde CO Alarm

---

## About Your CO Alarm

While many other CO alarms require costly sensors or a proprietary battery pack replacement, there are no replacement parts on Kidde CO alarms and they use standard alkaline batteries (if equipped).

### *Kidde CO Alarm – front view*

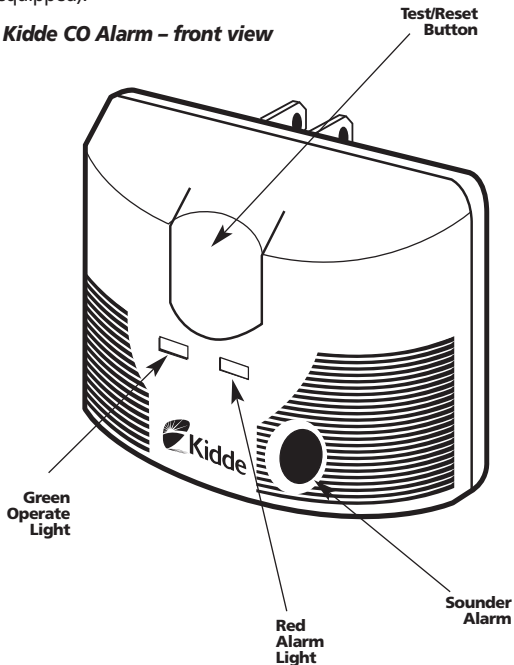

# Part One – Your Kidde CO Alarm

## *Kidde CO Alarm – rear view*

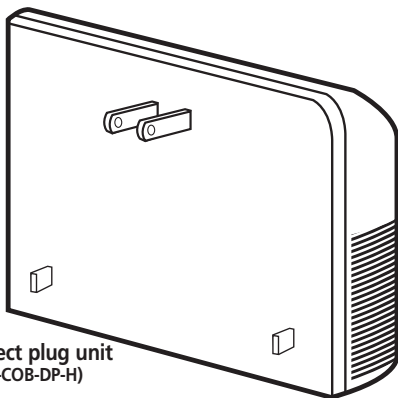

**Direct plug unit  
(KN-COB-DP-H)**

**Tamper-Resist  
Disable Switch**

**Tamper-Resist Activation Switch**  
See Normal Operating Characteristics

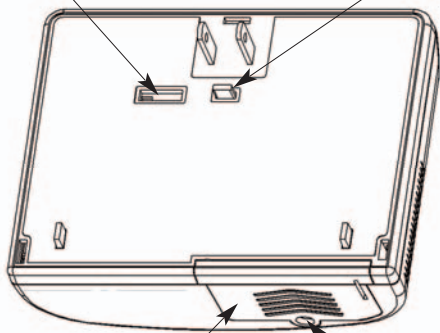

**9Volt Battery Door**

**Screw**  
(Used With Tamper-Resist Feature)

**Direct plug unit with battery backup  
(KN-COB-LCB-A)**

# Part One – Your Kidde CO Alarm

---

## **This Kidde Alarm's Unique Features**

### ***Test/Reset Button***

This button has two functions:

- 1) Press this is the button to test the unit weekly.
- 2) Press this button if the unit alarms to silence the alarm. This will reset the unit and it will then start monitoring for CO. If the CO concentration is above 70 ppm the alarm will again sound within 6 minutes.

### ***Sensor***

The sensor is a highly sensitive, electrochemical sensor that is CO-specific to help avoid false alarms.

### ***Sounder Alarm***

This is the loud 85 decibel pulsing alarm that will sound to alert you to a potential problem.

### ***9V Backup Battery (Model KN-COB-LCB-A only)***

This CO alarm is not battery operated; the 9V battery is to supply a short-term backup during a power outage. In the event of a power outage, the 9V battery will continue operating the alarm for at least 20 hours.

### ***Low Battery HUSH® (Model KN-COB-LCB-A only)***

By pressing the button on the CO alarm while it is in low battery mode you can stop the alarm from producing a low battery warning for up to twelve hours in order to maintain protection without having to replace the battery at an inconvenient time.

### ***Tamper-Resist Feature (Model KN-COB-LCB-A only)***

This is an alert to notify consumers the unit has been unplugged or has come loose from the outlet. This feature is not activated for two minutes after power is first supplied to give you time to plug the unit in after activating the battery. This feature is also disabled once the battery voltage has reached a level to cause a low battery warning chirp. This can be defeated for two minutes by pressing the Test button while the unit is removed from the plug to allow the battery to be changed without the 85dB alarm sounding. The feature can also be disabled by pressing in the Tamper-Resist Activation switch and moving the disable slide towards the switch. Use the included screw to secure the battery cover and increase tamper resistance.

## Part One – Your Kidde CO Alarm

---

### **What Carbon Monoxide Alarms Can and Cannot Do**

CO alarms are designed to sense unacceptable levels of CO from malfunctioning furnaces, appliances, gas engines, or other sources. This Carbon Monoxide alarm is not a substitute for installing and maintaining an operational smoke alarm.

CO alarms provide early warning of the presence of carbon monoxide, usually before a healthy adult would experience symptoms.

This early warning is possible, however, only if your Kidde CO alarm is located, installed and maintained as described in this user's guide.

CO alarms have limitations. Like any other electronic device, CO alarms are not fool-proof.

CO alarms have a limited operational life. You must test your CO alarm weekly, because it could fail to operate at any time. If your CO alarm fails to test properly, or if its self-diagnostic test reveals a malfunction, immediately have the alarm replaced.

CO alarms will not work without power. This CO alarm requires a continuous supply of electric power. This CO alarm is designed to act as a monitor, it is not designed for use as a short term testing device to perform a quick check for the presence of CO.

CO alarms can only sense CO that reaches the CO alarm's sensor. Carbon monoxide may be present in other areas without reaching the alarm. The rate at which CO reaches the alarm may be affected by doors or other obstructions. In addition, fresh air from a vent or open window or any other source may prevent CO from reaching the sensor.

CO could be present on one level of the home and not reach a CO alarm installed on a different level. For example, CO in the basement may not reach a alarm on the second level, near the bedrooms. For this reason, we recommend you provide complete coverage by placing a CO alarm on every level of the home.

CO alarms should not be used to detect the presence of natural gas (methane), propane, butane, or other combustible fuels.

CO alarms are not a substitute for property, disability, life or other insurance of any kind. Appropriate insurance coverage is your responsibility. Consult your insurance agent.

# Part One – Your Kidde CO Alarm

---

## Where to Install Your CO Alarm

Your Kidde CO alarm should be mounted in or near bedrooms and living areas. It is recommended that you install a Kidde CO alarm on each level of a multi-level home. You may use the number and location of smoke alarms installed in your home according to current building code requirements as a guide to the location of your Kidde CO alarm(s).

### RECOMMENDED LOCATIONS

#### UPPER LEVELS OF HOME

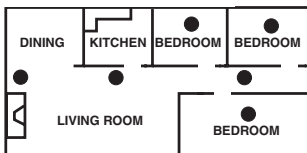

**WHEN CHOOSING YOUR INSTALLATION LOCATIONS, MAKE SURE YOU CAN HEAR THE ALARM FROM ALL SLEEPING AREAS. IF YOU INSTALL ONLY ONE CARBON MONOXIDE ALARM IN YOUR HOME, INSTALL THE ALARM NEAR BEDROOMS, NOT IN THE BASEMENT OR FURNACE ROOM.**

Two labels have been provided. Add the phone number of your Emergency Service provider in the space provided on the labels. Place one label next to the alarm and the other one near a fresh air source such as a door or window.

Seven (7) years after initial power up, this unit will “chirp” every 30 seconds to indicate that it is time to replace the alarm. **REPLACE IMMEDIATELY! IT WILL NOT DETECT CO IN THIS CONDITION.**

To help identify the date to replace the unit, a label has been affixed to the side of the alarm. Write the “Replace by” date (7 years from power up) in permanent marker on the label.

**CAUTION:** This CO alarm will only indicate the presence of carbon monoxide at the sensor. Carbon monoxide may be present in other areas.

**IMPORTANT:** Improper location can affect the sensitive electronic components in this CO alarm. Please see the next section describing where NOT to install this CO alarm.

# Part One – Your Kidde CO Alarm

---

## Where **Not** to Install Your CO Alarm

To avoid causing damage to the CO alarm, to provide optimum protection, and to prevent unnecessary alarms, follow the directions below where **NOT** to install this CO alarm:

It is recommended that you **DO NOT** install this CO alarm in garages, kitchens or furnace rooms. Installation in these areas could lead to nuisance alarms, may expose the sensor to substances that could damage or contaminate it, or the alarm may not be heard by persons in other areas of the home, especially if they are sleeping.

In the garage, vehicle exhaust can contain some carbon monoxide. These levels are higher when the engine is first started. CO levels in a garage may not be sufficient to activate the alarm immediately. Within hours of starting a vehicle and backing it out of the garage, the levels present over time can activate the alarm and become a nuisance.

In the kitchen and furnace room, some gas appliances can emit a short burst of carbon monoxide upon startup. This is normal. If your CO alarm is mounted too close to these appliances, it may alarm often and become a nuisance. If you must install a Kidde CO alarm near a cooking or heating appliance, **install at least 5 feet away from the appliance.**

Do not install in excessively dusty, dirty or greasy areas. Dust, grease or household chemicals can contaminate or coat the alarm's sensor, causing the unit not to operate properly.

Do not obstruct the vents of the CO alarm. Place the CO alarm where drapes, furniture or other objects do not block the flow of air to the vents.

Do not install in dead air space, such as peaks of vaulted ceilings or gabled roofs, where carbon monoxide may not reach the sensor in time to provide early warning.

Do not install in turbulent air from ceiling fans. Do not install near doors and windows that open to the outside, near fresh air vents, or anywhere that is drafty. Rapid air circulation from fans or fresh air from outside may affect the unit's alarm response time.

Do not install this CO alarm in a switch- or dimmer-controlled outlet.

Do not install in areas where the temperature is colder than 40°F (4.4°C) or hotter than 100°F (37.8°C). These areas include unconditioned crawl spaces, attics, porches and garages. Extreme temperatures will affect the sensitivity of the CO alarm.

## Part One – Your Kidde CO Alarm

---

Do not install CO alarm near deep cell large batteries. Large batteries have emissions that can cause the CO alarm to perform at less than optimal performance.

The following conditions can result in transient CO situations:

- Excessive spillage or reverse venting of fuel burning appliances caused by outdoor ambient conditions, such as:
  - 1) Wind direction and/or velocity, including high gusts of wind. Heavy air in the vent pipes (cold/humid air with extended periods between cycles).
  - 2) Negative pressure differential resulting from the use of exhaust fans.
  - 3) Simultaneous operation of several fuel burning appliances competing for limited internal air.
  - 4) Vent pipe connections vibrating loose from clothes dryers, furnaces or water heaters.
  - 5) Obstructions in or unconventional vent pipe designs which can amplify the above situations.
- Extended operation of unvented fuel burning devices (range, oven, fireplace, etc.).
- Temperature inversions which can trap exhaust gasses near the ground.
- Car idling in an open or closed attached garage, or near a home.

### How To Install Your Alarm

**Direct Plug Unit** (KN-COB-DP-H and KN-COB-LCB-A)

To install:

1. Choose a standard unswitched 120 volt out let to plug the unit into.
2. For model KN-COB-LCB-A, pull the Yellow tab to activate the battery
3. Plug the alarm into an unswitched wall socket.

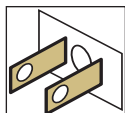

**CAUTION:** Do not rotate unit while it is plugged into an outlet, as damage to plug may result.

### Normal Operating Characteristics

**When you first power up the alarm**, the red alarm light will come on and the alarm will sound briefly, then the green operate light will come on. This is to show that the CO alarm is receiving power and that the alarm circuit is functioning.

Within a few minutes, your carbon monoxide alarm will start monitoring for CO and will continue to do so as long as it receives power.

## Part One – Your Kidde CO Alarm

---

**When the Model KN-COB-DP-H CO alarm is unplugged or loses power,** a fading alarm will sound briefly to alert you that it has been disconnected from its power source. For example, this fading alarm will sound in the event of a power outage. A brief alarm will also sound to alert you when the power is restored.

**THIS CO ALARM WILL NOT OPERATE WITHOUT 120V AC POWER.**

**When the Model KN-COB-LCB-A CO alarm loses power:** If you have a good 9V battery installed, the alarm will automatically switch to its battery backup mode and you will notice the green LED flashing approximately every 10 seconds. The unit will continue to operate normally and detect CO for at least 20 hours.

When AC power is restored, the alarm will automatically switch back to normal operating mode and the green LED will come on continuously.

**When the Model KN-COB-LCB-A CO alarm is unplugged:** If the unit is unplugged it will produce a constant tone until the battery is removed or the unit is plugged back into the wall unless the Tamper-Resist feature has been deactivated or disabled as described in the feature section.

### Testing the Electronics

You should test the alarm once a week, following the directions listed below. If at any time you test the alarm and it does not perform as described below, have it replaced immediately. See the following section for a description of the characteristics of a malfunctioning alarm and what you should do if a malfunction occurs.

Observe the CO alarm regularly to make sure the green operate light is on, indicating normal operation.

If the green operate light is not on, unplug the CO alarm, then plug it in again. This will clear the alarm for restart. If the green operate light does not come back on, your CO alarm may be malfunctioning.

**To test the CO alarm,** press and release the Test/Reset button, you will hear 4 quick beeps – followed by 5 seconds of silence – followed by 4 quick beeps. Notice the Red Alarm Light flashes when the unit alarms. The alarm will then return to monitoring for carbon monoxide.

**NOTE:** Pressing the Test/Reset button tests the functions of the CO alarm's internal components, circuitry and micro-computer.

**YOU DO NOT NEED TO PRESS THE TEST BUTTON TO TAKE A CO READING.**

**Caution:** Continuous exposure to the loud 85 decibel alarm at close range over an extended period of time may cause hearing loss.

# Part One – Your Kidde CO Alarm

## How to Know If Your Alarm is Malfunctioning

Your CO alarm performs an internal self-diagnosis every fifteen seconds to make sure that it is functioning properly. The CO alarm is designed to alert you in the unusual event of a malfunction.

### If the alarm malfunctions.

In the rare event that your alarm malfunctions, it will alert you with one of these signal groups (depending upon the type of malfunction that occurs):

#### **Malfunction Signal Group 1 - Component Failure**

- An intermittent “chirping” alarm will sound every 30 seconds.

**OR,**

#### **Malfunction Signal Group 2 - Microprocessor Failure**

- The alarm will sound continuously, and
- The alarm cannot be shut off by pushing the “Test/Reset”

button

Unplug the CO alarm immediately and return for warranty exchange.

#### **Low Battery Warning (Model KN-COB-LCB-A only)**

If the 9V battery is missing or the battery’s power is low, the unit will chirp every 15 second to indicate the battery must be replaced. If the battery is depleted beyond point of having the capacity to operate the unit, it will chirp every 30 to 45 seconds and will **NOT** respond to the test button being pressed if operating on battery power. **THE BATTERY MUST BE REPLACED IMMEDIATELY!**

#### **Low Battery HUSH<sup>®</sup> CONTROL (Model KN-COB-LCB-A only)**

When the battery needs to be replaced, the unit will produce a low battery warning. The Low Battery HUSH<sup>®</sup> feature allows you to press the button on the alarm and disable the “chirp” for a random period of up to 12 hours. This gives you a chance to replace the battery at a more convenient time without sacrificing your safety by disconnecting the alarm from power. During this Low Battery HUSH<sup>®</sup> period, your alarm is monitoring for CO.

#### **What to do if you’re not sure...**

PLEASE familiarize yourself with the malfunction alert, and do not confuse these signals with an alarm. After reading the information above, if you are still unsure whether your CO alarm is operating properly, call the Kidde toll-free consumer hotline at 1 800-880-6788 to do a quick diagnostic check of the alarm over the phone. The customer service representative will be able to assist you and answer your questions.

## Part One – Your Kidde CO Alarm

---

Never ignore a CO unit's alarm. A true alarm is an indication of potentially dangerous levels of carbon monoxide. CO alarms are designed to alert you to the presence of carbon monoxide before an emergency and before most people would experience symptoms of carbon monoxide poisoning.

### How to Replace the Battery in Your Model KN-COB-LCB-A

Remove the screw, if it has been used, that is holding the battery door located on the bottom of the unit. Slide the battery door in the direction of the arrows to release it. Remove the battery and replace it with one of the following approved replacement batteries:

- Energizer 522
- Duracell MN1604
- Ultralife lithium U9VL

Replace the battery door and re-install the screw if it is used.

Any of these batteries can be purchased where you bought the alarm or at your local hardware store.

Constant exposures to high or low humidity may reduce battery life.

We recommend you replace your 9V battery at least every six months.

### How to Care for Your CO Alarm

To keep your CO alarm in good working order, you must follow these simple steps:

#### WHAT YOU SHOULD DO:

- Test the CO alarm once a week by pressing the Test/Reset button.
- Vacuum the alarm cover once a month to remove accumulated dust. Use the soft brush attachment of your vacuum cleaner, and unplug the CO alarm from the electrical outlet before vacuuming.
- Instruct children never to touch, unplug or otherwise interfere with the unit. Warn children of the dangers of CO poisoning.

#### WHAT YOU SHOULD NOT DO:

- Never use detergents or solvents to clean the CO alarm. Chemicals can permanently damage or temporarily contaminate the sensor.
- Avoid spraying air fresheners, hair spray, paint or other aerosols near the CO alarm.
- Do not paint the CO alarm. Paint may seal the vents and interfere with proper sensor operation.

## Part One – Your Kidde CO Alarm

---

- Do not mount the CO alarm directly above or near a diaper pail.

Note: If you will be staining or stripping wood floors or furniture, painting, wall-papering, or using aerosols or adhesives for a do-it-yourself project or hobby, **before you begin: Remove the CO alarm to a remote location to prevent possible damage to or contamination of the sensor.** You may wish to unplug the CO alarm and store it in a plastic bag during the project.

The following is a list of substances which, at high levels, can affect the sensor and may cause a nuisance alarm that is not a carbon monoxide alarm.

**Methane, propane, iso-butane, ethylene, ethanol, alcohol, iso-propanol, benzene, toluene, ethyl acetate, hydrogen, hydrogen sulfide, sulfur dioxides, most aerosol sprays, alcohol based products, paints, thinners, solvents, adhesives, hair spray, after shave, perfume, auto exhaust (cold start) and some cleaning agents.**

## Part Two – Carbon Monoxide

---

### The Effects of CO Exposure.

When you breathe carbon monoxide, it enters your bloodstream through your lungs and attaches to red blood cells. These red blood cells, called hemoglobin, carry oxygen throughout your body. Carbon monoxide molecules attach to the red blood cells 200 times faster than oxygen, preventing the flow of oxygen to your heart, brain and vital organs. As carbon monoxide accumulates in your bloodstream, your body becomes starved for oxygen. The amount of carbon monoxide in a person's body can be measured by a simple blood test, called a "carboxyhemoglobin level" test .

The early symptoms of carbon monoxide poisoning are often mistaken for the flu – headache, dizziness, weakness, nausea, vomiting, sleepiness, and confusion.

### Could Your Family be at Risk for CO Poisoning?

Carbon monoxide is the number one cause of poisoning deaths in the United States. According to the Mayo Clinic, at least 10,000 Americans are affected by CO poisoning each year.

While anyone is susceptible, experts agree that unborn babies, small children, senior citizens and people with heart or respiratory problems are especially vulnerable to CO and are at the greatest risk for death or serious injury.

## Part Two – Carbon Monoxide

---

### Where CO Comes From.

Inside your home, appliances used for heating and cooking are the most likely sources of carbon monoxide. Vehicles running in attached garages can also produce dangerous levels of carbon monoxide in your home.

A by-product of combustion, carbon monoxide can be a potential problem from a number of common sources – automobiles, furnaces, water heaters, fireplaces, wood stoves, charcoal grills, gas ranges, space heaters and portable generators.

When these appliances are in good working condition with proper ventilation, lethal carbon monoxide gas is vented outdoors where it quickly disperses. But even the slightest malfunction or misuse of any of these sources can lead to a build-up of carbon monoxide in your home that can become deadly before you'd know it's there.

You don't have to have ancient appliances to have a problem. Today's more energy-efficient, airtight home designs can trap CO-polluted air inside where it can quickly build to lethal levels.

### Protecting Your Family from CO poisoning.

To be safe, know the possible sources of CO in your home. Keep fuel-burning appliances and their chimneys and vents in good working condition. Learn the early symptoms of CO exposure, and if you suspect carbon monoxide poisoning, move outside to fresh air and get emergency help.

Your first line of defense is an annual inspection and regular maintenance of your appliances. Contact a licensed contractor or call your local utility company for assistance.

Problems can begin after an inspection is over, like a crack in a furnace heat exchanger, or a leak in a water heater vent or a bird's nest blocking a flue or other sources that are nearly impossible to detect. That's why you need the 24-hour protection provided by a CO alarm.

### Home Safety Tips

#### What You Can Do...

- Buy only appliances approved by a nationally recognized testing laboratory.
- Choose fuel-burning appliances that can be vented to the outdoors, whenever possible.
- Make sure appliances are installed according to manufacturer's instructions and local building codes. Most appliances should be installed by professionals and should be inspected by the proper authority after installation.

## Part Two – Carbon Monoxide

---

- Have the heating system, vents, chimney and flue inspected and cleaned by a qualified technician every year.
- Follow manufacturer's directions for safe operation of all fuel-burning appliances.
- Examine vents and chimneys regularly for improper connections, visible rust or stains.
- Open a window when a fireplace or wood-burning stove is in use, and provide adequate outdoor air for furnace and water heater.
- Notice problems that could indicate improper appliance operation:
  - Decreasing hot water supply
  - Furnace unable to heat house or runs constantly
  - Sooting, especially on appliances
  - Unfamiliar or burning odor
  - Yellow or orange flame
- Be aware of the symptoms of carbon monoxide poisoning:
  - headaches, dizziness, weakness, sleepiness, nausea, vomiting, confusion and disorientation.
- Recognize that CO poisoning may be the cause when family members suffer from flu-like symptoms that don't disappear but improve when they leave home for extended periods of time.

### What You Should Not Do...

- Never burn charcoal inside a home, garage, cabin, RV or camper.
- Never install, service, or convert fuel-burning appliances from one type to another without proper knowledge, skills, and tools.
- Never use a gas range, oven, or clothes dryer for heating.
- Never operate unvented gas-burning appliances, such as kerosene or natural gas space heaters, in a closed room.
- Never operate gasoline-powered engines (like vehicles, motorcycles, lawn mowers, yard equipment or power tools) in confined areas such as garages or basements, **even if** an outside door or window is open.
- Never ignore a safety device when it shuts off an appliance.
- Never ignore a CO alarm.

## Part Two – Carbon Monoxide

---

### **Be Aware of the Warning Signs of Carbon Monoxide: Clues You Can See...**

- Streaks of carbon or soot around the service door of your fuel-burning appliances.
- A yellow or orange flame may indicate a problem with natural gas appliances.
- Excessive rusting on flue pipes or appliance jackets.
- Loose or missing furnace panel.
- Moisture collecting on the windows and walls of furnace rooms.
- Loose or disconnected vent/chimney, fireplace or appliance.
- Small amounts of water leaking from the base of the chimney, vent or flue pipe.
- Rust on the portion of the vent pipe visible from outside your home.
- The absence of a draft in your chimney (indicating blockage).
- Fallen soot from the fireplace chimney.
- Loose, damaged or discolored bricks on your chimney.

### **Clues You Cannot See...**

- Internal appliance damage or malfunctioning components.
- Improper burner adjustment.
- Hidden blockage or damage in chimneys.

## Part Three – Understand the Effects of Carbon Monoxide Exposure

---

### Understand the Effects of Carbon Monoxide Exposure

| <b>Concentration of CO in Air<br/>(ppm = parts per million)</b> | <b>Approximate Inhalation Time and Symptoms Developed</b>  |
|---|--|
| <b>50 ppm</b>   | The maximum allowable concentration for continuous exposure for healthy adults in any 8-hour period, according to OSHA*. |
| <b>200 ppm</b>  | Slight headache, fatigue, dizziness, nausea after 2-3 hours.   |
| <b>400 ppm</b>  | Frontal headaches within 1-2 hours, life threatening after 3 hours.  |
| <b>800 ppm</b>  | Dizziness, nausea and convulsions within 45 minutes. Unconsciousness within 2 hours. Death within 2-3 hours.             |
| <b>1 600 ppm</b>  | Headache, dizziness and nausea within 20 minutes. Death within 1 hour.   |
| <b>3 200 ppm</b>  | Headache, dizziness and nausea within 5-10 minutes. Death within 25-30 minutes.  |
| <b>6 400 ppm</b>  | Headache, dizziness and nausea within 1-2 minutes. Death within 10-15 minutes.   |
| <b>12 800 ppm</b>   | Death within 1-3 minutes.  |

*\* Occupational Safety and Health Administration*

**Reminder:** The chart above relates to the exposure of healthy adults.

## Part Four – What to do When the Alarm Sounds

---

Determine if anyone in the household is experiencing symptoms of CO poisoning. Many cases of reported CO poisoning indicate that while victims are aware they are not well, they become so disoriented that they are unable to save themselves by either exiting the building or calling for assistance. Also young children, older family members, and household pets may be the first affected. The following symptoms are related to CARBON MONOXIDE POISONING and should be discussed with ALL members of the household:

**Common Mild Exposure Symptoms:**

Headaches, running nose, sore eyes, often described as “flu” like symptoms.

**Common Medium Exposure Symptoms:**

Dizziness, drowsiness, vomiting

**Common Extreme Exposure Symptoms:**

Unconsciousness, brain damage, death.

*Become familiar with these common symptoms from CO poisoning.*

*If you experience even mild symptoms of CO poisoning, consult your doctor immediately!*

## Part Four – What to do When the Alarm Sounds

---

### Carbon Monoxide Alarm Procedure



**WARNING:** Actuation of the CO Alarm indicates the presence of Carbon Monoxide (CO) which can kill you.

If alarm signal sounds:

- 1) Operate the Test/Reset Button
- 2) Call your emergency services (Fire Dept. or 911).
- 3) Immediately move to fresh air - outdoors or by an open door or window. Do a head count to check that all persons are accounted for. Do not re-enter the premises nor move away from an open door or window until the emergency services responders have arrived, the premises has been aired out, and your alarm remains in it's normal condition.
- 4) After following steps 1-3, if your alarm reactivates within a 24 hour period, repeat steps 1-3 and call a qualified appliance technician to investigate for sources of CO from fuel burning equipment and appliances, and inspect for proper operation of this equipment. If problems are identified during this inspection, have the equipment serviced immediately. Note any combustion equipment not inspected by the technician and consult the manufacturer's instructions, or contact the manufacturer directly for more information about CO safety and this equipment. Make sure that motor vehicles are not, and have not been, operating in an attached garage or adjacent to the residence.

## Part Five – Technical Information

---

**Power:** 120V AC units: 60 Hz, Current 60 mA max. 9V Battery Backup for Model KN-COB-LCB-A

**Sensor:** Sensor calibrated at 150 ppm ( $\pm 25$  ppm).

**Temperature:**

Operating range: 40°F (4.4°C) to 100°F (37.8°C).

**Mounting:** **Direct Plug-In:** No mounting screws needed.

**Alarm:** 85+ dB at 10' @  $3.4 \pm 0.5$  KHz pulsing alarm.

**This CO alarm meets response time requirements as follows:**

At 70 ppm, the unit must alarm within 60-240 minutes.

At 150 ppm, the unit must alarm within 10-50 minutes.

At 400 ppm, the unit must alarm within 4-15 minutes.

### **How the CO alarm determines when to alarm**

Your Kidde CO alarm uses advanced technology to monitor the environment in your home and warn you of unacceptable levels of carbon monoxide. An internal microcomputer works together with the carbon monoxide sensor inside the alarm to determine the levels of carbon monoxide in the air and to calculate the rate that CO would be absorbed into the human body.

The microcomputer is calibrated to trigger the alarm before most people would experience any symptoms of carbon monoxide poisoning. Because carbon monoxide is a cumulative poison, long-term exposures to low levels can cause symptoms, as well as short-term exposures to high levels. Your Kidde CO alarm has a time weighted alarm, so the higher the level of carbon monoxide present, the sooner the alarm will be triggered.

## Limited Warranty

---

WARRANTY COVERAGE: THE MANUFACTURER WARRANTS TO THE ORIGINAL CONSUMER PURCHASER, THAT THIS PRODUCT, EXCLUDING THE BATTERY, WILL BE FREE OF DEFECTS IN MATERIAL AND WORKMANSHIP FOR A PERIOD OF FIVE (5) YEARS FROM DATE OF PURCHASE. THE MANUFACTURER'S LIABILITY HEREUNDER IS LIMITED TO REPLACEMENT OF THE PRODUCT. REPAIR OF THE PRODUCT OR REPLACEMENT OF THE PRODUCT WITH REPAIRED PRODUCT AT THE DISCRETION OF THE MANUFACTURER. THIS WARRANTY IS VOID IF THE PRODUCT HAS BEEN DAMAGED BY ACCIDENT, UNREASONABLE USE, NEGLIGENCE, TAMPERING OR OTHER CAUSES NOT ARISING FROM DEFECTS IN MATERIAL OR WORKMANSHIP. THIS WARRANTY EXTENDS TO THE ORIGINAL CONSUMER PURCHASER OF THE PRODUCT ONLY.

Warranty Disclaimers: Any implied warranties arising out of this sale, including but not limited to the implied warranties of description, merchantability and fitness for a particular purpose, are limited in duration to the above warranty period. In no event shall the Manufacturer be liable for loss of use of this product or for any indirect, special, incidental or consequential damages, or costs, or expenses incurred by the consumer or any other user of this product, whether due to a breach of contract, negligence, strict liability in tort or otherwise. The Manufacturer shall have no liability for any personal injury, property damage or any special, incidental, contingent or consequential damage of any kind resulting from gas leakage, fire or explosion.

Some provinces do not allow limitations on how long an implied warranty lasts, so the above limitation may not apply to you.

Some states do not allow the exclusion or limitation of consequential or incidental damages, so the above limitations or exclusions may not apply to you.

Legal Remedies: This warranty gives you specific legal rights and you may also have other rights that vary from state to state.

Warranty Performance: During the above warranty period, your product will be replaced with a comparable product if the defective product is returned, postage prepaid, to Kidde, Customer Service Department, 1-800-880-6788 together with proof of purchase date. Please include a note describing the problem when you return the unit. The replacement product will be in warranty for the remainder of the original warranty period or for six months, whichever is longer. Other than the cost of postage, no charge will be made for replacement of the defective product.

*Important:* Do not remove back cover. Back cover removal will void warranty.

Your *Kidde Carbon Monoxide Alarm* is not a substitute for property, disability, life or other insurance of any kind. Appropriate insurance coverage is your responsibility. Consult your insurance agent.