

# SERVICE BULLETIN



## 854

# Replacement of I/O Assembly, PGU Assembly, Brake and Motor Magnet Housing

### Purpose

This Service Bulletin includes instructions for replacing the I/O Assembly of the 854 Benders.

This Service Bulletin also provides instructions for replacing the PGU Assembly, Brake, and Motor Magnet Housing. Please refer to the 854 Instruction Manual IM 1301 or SB 276 for troubleshooting information.



**Read and understand** this material and the bender instruction manual IM 1301 before servicing this tool. Failure to understand how to safely operate this tool can result in an accident causing severe injury or death.

## I/O Assembly Replacement

Refer to illustration for location of components and connections.

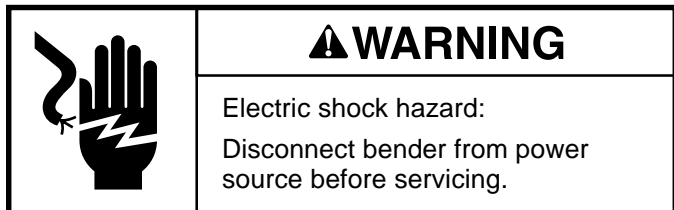

1. Place unit in vertical position.
2. Remove four screws securing the cover and remove cover.
3. Unplug the two pin connector (8) from the location marked BRAKE.
4. Unplug the four pin connector (9) from the location marked DIR. SWITCH.
5. Unplug the four pin connector (7) from the location marked 120 VAC
6. Unplug the six pin connector (1) from the location marked TO PGU.
7. Disconnect the motor lead (2) from the relay.
8. Disconnect the red wire (4) between the two relays from the relay on the I/O assembly.
9. Remove the white wire (5) from the brake resistor to the relay on the PGU assembly.
10. Remove the four mounting screws.
11. Remove the I/O Assembly.
12. Assemble in reverse order.

## PGU Assembly Replacement

Refer to illustration for location of components and connections.

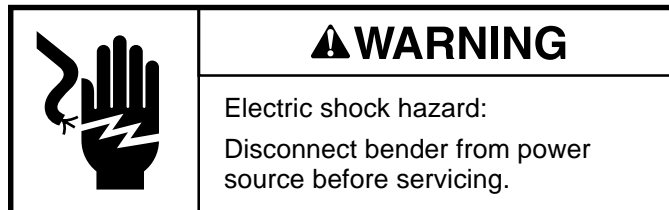

1. Place unit in vertical position.
2. Remove four screws securing the cover and remove cover.
3. Disconnect the black wire in (7) and black wire (6) from the terminal block position labeled LINE.
4. Disconnect the white wire in (7) and white wire (10) from the terminal block position labeled NEUTRAL.
5. Disconnect the green wire in (7) from the terminal block position labeled GRD.
6. Unplug the six pin connector (1) from the location marked TO I/O.
7. Disconnect the motor lead (3) from the relay.
8. Disconnect the red wire (4) between the two relays from the relay on the PGU Assembly.
9. Disconnect the white brake resistor wire (5) from the relay.
10. Remove the four mounting screws.
11. Remove the PGU Assembly.
12. Assemble in reverse order.

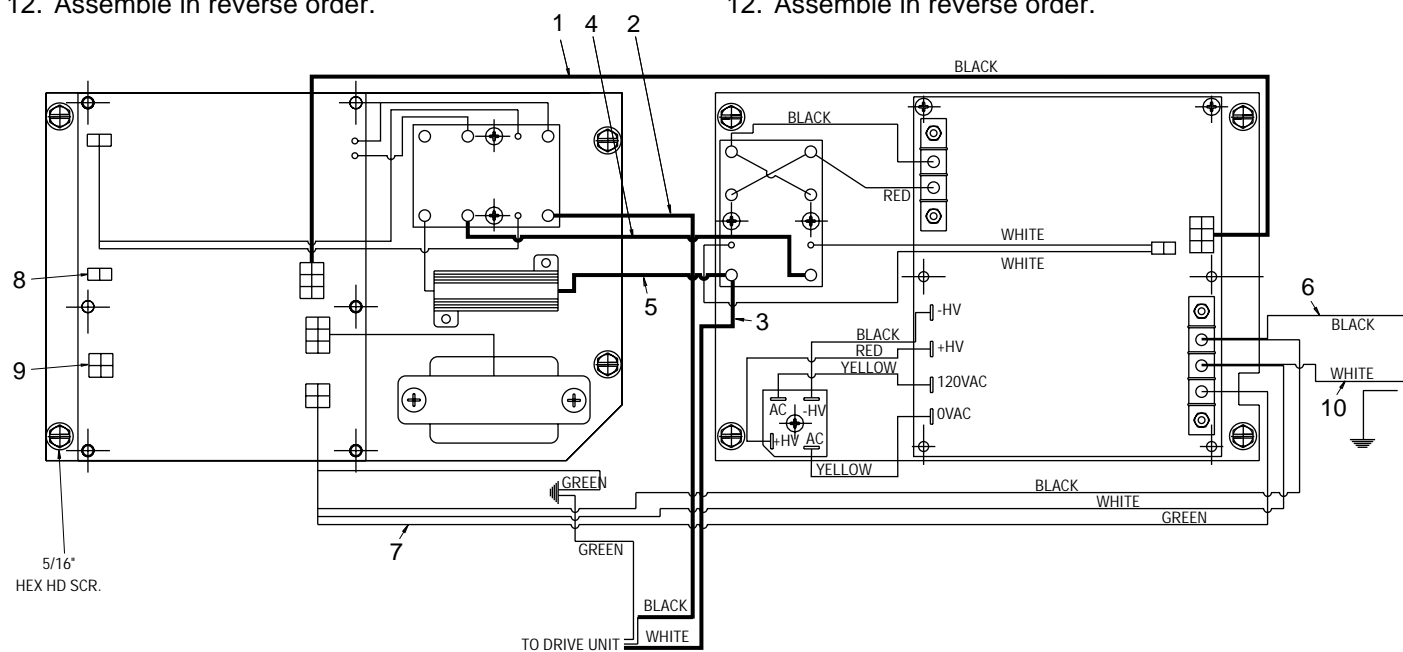

- |                          |                              |                              |
|--------------------------|------------------------------|------------------------------|
| 1. PGU—I/O Cable, 6 Wire | 5. White Brake Resistor Wire | 8. Brake Cable               |
| 2. Black Motor Lead      | 6. PGU to Circuit Breaker    | 9. Direction Switch Cable    |
| 3. White Motor Lead      | 7. I/O to Power Wire Unit    | 10. White Wire in Power Cord |
| 4. Red Jumper            |                              |                              |

## Brake Replacement

Refer to illustration.

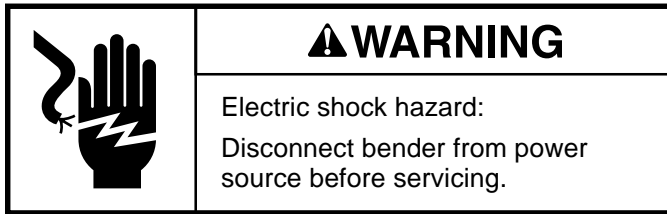

1. Remove four screws securing the cover and remove cover.
2. Unplug the two pin connector on the I/O board marked BRAKE.
3. Tie a string or small gage wire to the connector just unplugged to facilitate fishing the new brake wire into place.
4. Remove motor cover.
5. Remove the two set screws in the hex drive hub, and remove drive hub.
6. Remove the four socket head bolts attaching the brake to the motor housing. Remove brake.
7. Remove hex drive hub from new brake.
8. Mount the new brake to the motor housing using four 8–32 socket head bolts.
9. Check the three 10–32 outer plate bolts. If they have been loosened, re-torque them to 75 inch-pounds.
10. Install hex drive hub and the 1/8 x 1/8 key on motor shaft.  
*Note: If drive hub is off center, disconnect the I/O to PGU wire unit (item 1 electronic control illustration). Plug in and turn bender on and press BEND or UNLOAD. The brake will release the friction plate to allow the hex drive hub to be inserted. Turn off and disconnect power while completing procedure.*
11. Push the hex drive hub in until it contacts the armature plate.
12. Measure the distance from the hub to the motor shaft, then pull the hub out .020-.030" and tighten the two set screws.
13. Use a low strength thread-locking agent on the brake hub set screws.
14. Attach the string or wire from step 3 to the connector of the new brake, and pull the new brake wire up through the bender.
15. Plug the connector into the location on the I/O board marked BRAKE.
16. Replace the motor cover.
17. Replace the top cover and secure it with the four screws.

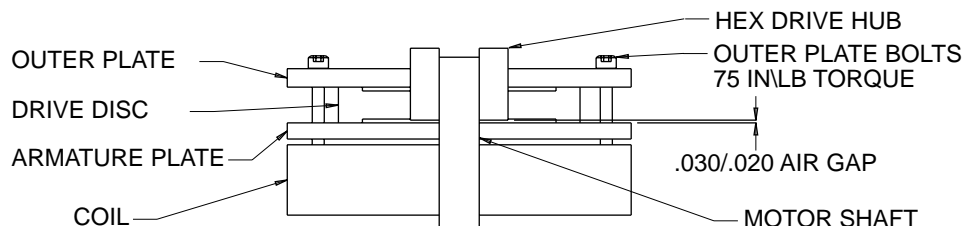

# Motor Magnet Housing Replacement

Refer to illustration.

	<b>⚠ WARNING</b>
	<p>Electric shock hazard: Disconnect bender from power source before servicing.</p>

1. Remove motor cover.
2. Remove the two set screws in the hex drive hub, and remove drive hub and the 1/8 x 1/8 key.
3. Remove two socket head cap screws on the motor shroud (6), then remove the shroud.
4. Remove the two brush retainers by pushing in and moving it towards the brush to release.
5. Remove the two nuts (10) and washers (11) on the tail housing (3), then remove the tail housing and brush holder assembly (4).

*Note:* The tail housing and brush holder assembly is located by a roll pin in the magnet housing. This roll pin must be facing outward when reinstalling the magnet housing (7).

6. Remove the motor magnet housing (7).

*Note:* If the armature (8) is pulled out when removing the magnet housing, remove it by clamping the gear end of the armature in a soft jawed vise, then separate the magnet housing from the armature.

7. Reverse the procedure to assemble the new magnet housing. (Refer to Assembly.)

# Assembly

1. Assemble all Belleville washers so that ID's butt and OD's contact bearings (9).
2. Tighten motor nuts (10) to 30-35 inch-pounds.
3. Insert commutator brushes before connecting push-on terminals.

KEY NO.	UPC NO. 78-3310-	PART NO.	DESCRIPTION
1	86705	918 6705.3	Commutator Brushes
2	86706	918 6706.1	Commutator Brush Retension Springs
3	86707	918 6707.0	Tail Housing
4	86708	918 6708.8	Brush Assembly Plate
5	86709	918 6709.6	Cord
6	39092	503 9092.9	Shroud
7	86710	918 6710.0	Magnet Housing
8	86711	918 6711.8	Armature
9	54348	905 4348.3	Belleville Washers
10	51705	905 1705.9	1/4"-28 Hex Nut
11	50749	905 0749.5	1/4" Internal Tooth Lockwasher

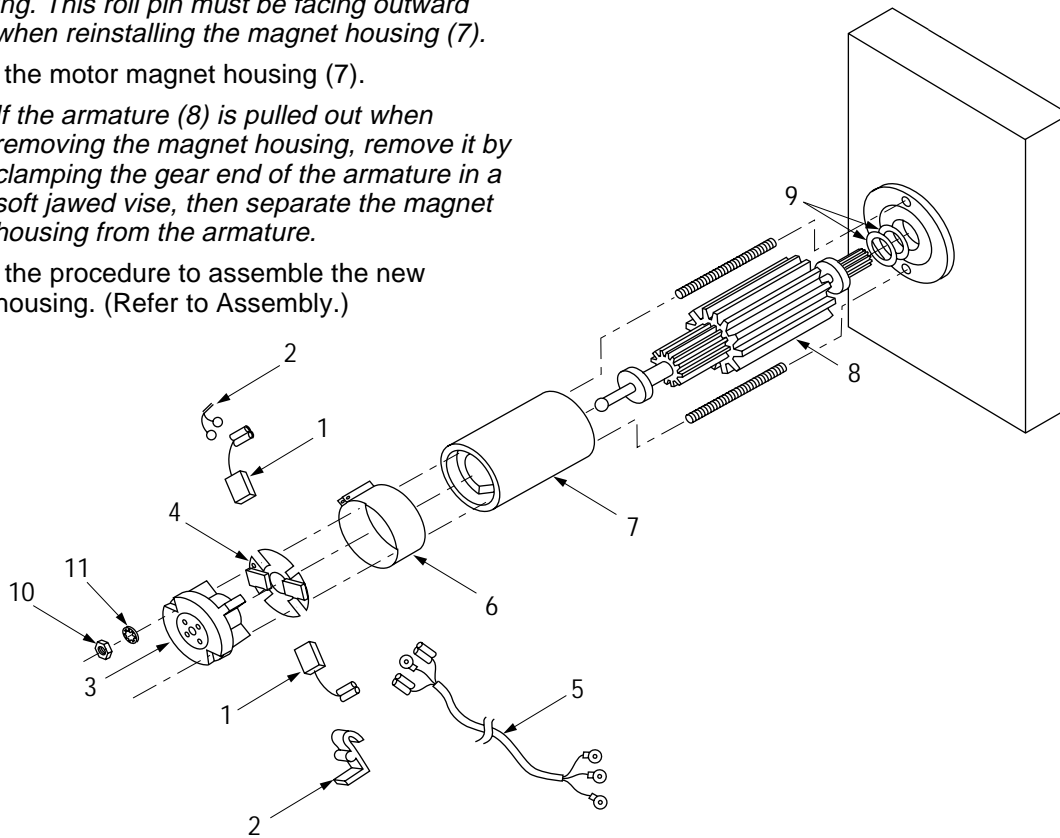

# GREENLEE **TEXTRON**

Greenlee Textron / Subsidiary of Textron Inc.