

A New^w Clamp that Struts its Stuff!

IPEX introduces Scepter® conduit clamps. Designed for use with PVC conduit, the new Conduit Clamps and Spacers (CCS) provide installation flexibility, strength and lasting reliability.

- No more performance concerns with nonmetallic conduit
- No need for tools, nuts or bolts for strut mounting
- No reliability issues when used in corrosive environments

Recognizing the need for a clamp with features to support the unique requirements of nonmetallic conduit systems, IPEX developed the CCS clamps. They are engineered to accommodate proper expansion and contraction of conduits and to prevent unwanted clamp opening. Other features incorporated into the design include multiple mounting options (see back) and the ability to be linked together – regardless of the size of the adjacent clamp.

Most importantly, the CCS supports the conduit away from the mounting surface and made of PVC, the straps are ideal for use in wash-down areas and in corrosive and/or wet location environments.

With mounting options and a simple push-in conduit installation technique, the CCS clamps save you time and are cost effective without sacrificing quality.

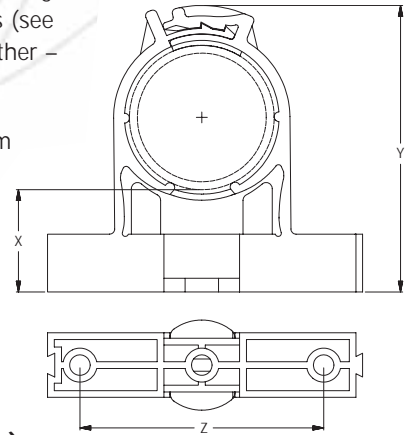

Dimensions (inches)

Size	Part Number	Product Code	X	Y	Z
1/2	CCS10	077794	1.191	2.414	1.824
3/4	CCS15	077796	1.195	2.660	2.106
1	CCS20	077797	1.215	2.962	2.443
1 1/4	CCS25	077798	1.182	3.300	2.855
1 1/2	CCS30	077799	1.193	3.600	3.170
2	CCS35	077800	1.195	4.135	3.785
Base	CCS-B	077343			



Features:

- Optional mounting methods
 - Single center hole
 - Two hole
 - Strut mounting (with accessory parts CCS-B)
- Interconnecting in all sizes for uniform row installation
- Friction reduction ribs to permit conduit expansion/contraction
- Double offset clip design prevents unwanted opening of clamp



FEATURES

Single center hole



Two hole



Strut mounting w/ accessory parts



Interconnecting in all sizes for uniform row installation



Friction reduction ribs to permit conduit expansion/contraction



Double offset clip design prevents unwanted opening of clamp



STRUT BASE ASSEMBLY



STRUT MOUNT INSTALLATION

